



# 336

## Soft Serve Freezer

Twin Twist

### Features

Offer all the popular soft serve variations from low or non-fat ice creams to custards, yogurt and sorbet. Serve two separate soft serve flavors, or an equal combination of both in a twist.

### Freezing Cylinder

Two, 2.8 quart (2.7 liter).

### Mix Hopper

Two, 8 quart (7.6 liter). Separate hopper refrigeration (SHR) maintains mix below 41°F (5°C) in Auto and Standby modes.

### Indicator Lights

The Mix Low light alerts the operator to add mix. Audible alarm may be enabled to sound when mix is low.

### Electronic Controls

Finished product quality is monitored by Softech™ controls that measure viscosity.

### Standby

During long no-use periods, the standby feature maintains safe product temperatures in the mix hopper and freezing cylinder.

### Two Locking Casters

Front casters have a locking feature for operators to lock to maintain equipment in place. The locking casters can be released to move the equipment for cleaning.

### Freezer Door

A specially designed thermo-plastic door allows quick ejection of product with a simple movement of the draw handle. Self closing draw handles are standard.



# 336 Soft Serve Freezer

336

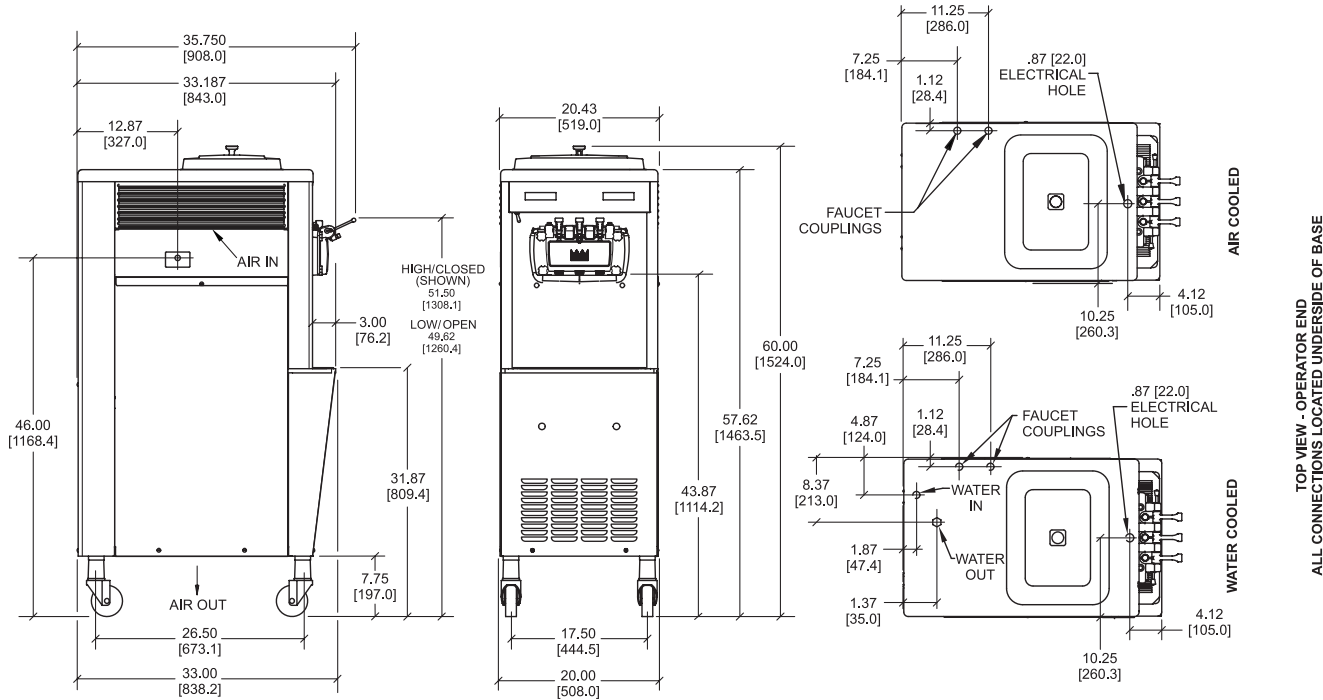

FIGURES IN BRACKETS INDICATE MILLIMETERS / DECIMAL DIMENSIONS EQUAL TO ( PLUS OR MINUS 1/16 INCH [1.5mm] ).

Weights	lbs.	kgs.
Net	520	235.9
Crated	551	249.9
	cu. ft.	cu. m.
Volume	48.1	1.36

Dimensions	in.	mm.
Width	20-7/16	519
Depth	33	839
Height	60	1524
Floor Clearance	7-3/4	197

\*Mounted on standard casters

Electrical	Maximum Fuse Size	Minimum Circuit Ampacity	Poles (P) Wires (W)
208-230/60/1 Air	35	27	2P 3W
208-230/60/1 Water	35	25	2P 3W
208-230/60/3 Air	20	18	3P 4W
208-230/60/3 Water	20	16	3P 4W
220-240/50/1 Air	30	23	2P 3W
380-415/50/3N~ Air	12	10	4P 5W

This unit may be manufactured in other electrical characteristics. Refer to the local Taylor Distributor for availability.

(For exact electrical information, always refer to the data label of the unit.)

## Bidding Specs

Electrical: Volt \_\_\_\_\_ Hz \_\_\_\_\_ ph \_\_\_\_\_  
 Neutral: Yes No **Cooling:** Air Water NA

Options: \_\_\_\_\_

## Specifications

### Electrical

One dedicated electrical connection is required. See the Electrical chart for the proper electrical requirements. Manufactured to be permanently connected. Consult your local Taylor distributor for cord & receptacle specifications as local codes allow.

### Beater Motor

Two, 1.0 HP

### Refrigeration System

One, 9,500 BTU/hr. R404A.  
 Separate Hopper Refrigeration (SHR), One, 400 BTU/hr. R134a.  
 (BTUs may vary depending on compressor used.)

### Air Cooled

Minimum 3" (76 mm) around all sides. Install the deflector provided to prevent recirculation of warm air. Minimum air clearances must be met to assure adequate air flow for optimum performance.

### Water Cooled

Water inlet and drain connections under side of base 3/8" FPT.

## Options

- Cone Dispenser
- Draw Valve Lock Kit
- Faucet
- Sneeze Guard
- Syrup Rail Kit (side mount)

Continuing research results in steady improvements; therefore, these specifications are subject to change without notice.



Taylor Company,  
 Rockton, Illinois 61072  
 815-624-8333 **800-255-0626** Fax 815-624-8000  
[www.taylor-company.com](http://www.taylor-company.com)