

# C002

## Continuous Dispensing Batch Freezer

Two Flavor

### Features

Offer super premium frozen custard, low overrun ice cream, or sorbet in two separate flavors.

#### Mix Hopper

Two, 20 quart (18.9 liter). Separate hopper refrigeration (SHR) maintains mix below 41°F (5°C).

#### Indicator Lights

In order from top to bottom, separate lights indicate when mix is low, refrigeration on, pre-chill mode, and scraping/ejection motor on.

#### Product Chute

Ribbon of frozen product flows down chute to separate dipping cabinet. Easily removable for cleaning or moving dipping cabinet.

#### Mix Flow Regulator

Easy to read markings allow operator to dial in the correct amount of mix flowing into freezing cylinder for proper consistency. Adjusts for operation from the front, back, or side, depending on space requirements.



Shown with separate dipping cabinet  
(Available through your local Taylor distributor)



# C002 Continuous Dispensing Batch Freezer

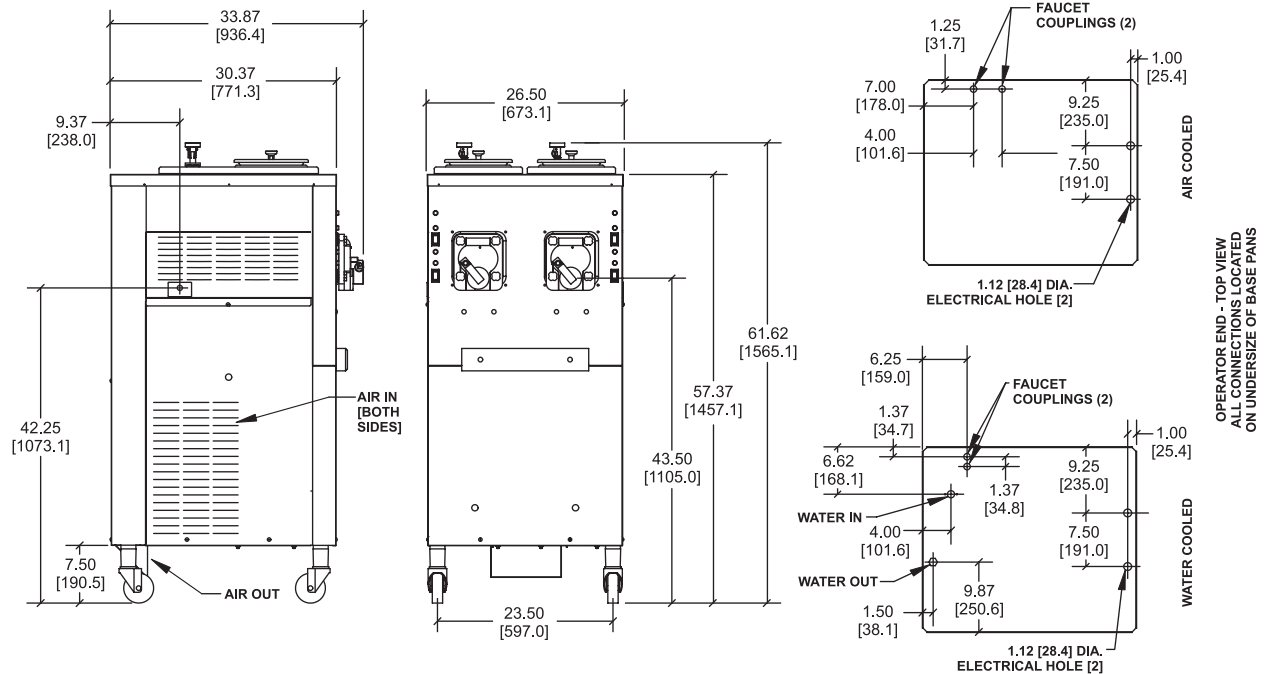

FIGURES IN BRACKETS INDICATE MILLIMETERS. DECIMAL DIMENSIONS EQUAL TO ( PLUS OR MINUS 1/16 INCH [1.5mm] ). \* WATER COOLED ONLY

| Weights | lbs.    | kgs.   |
|---------|---------|--------|
| Net     | 825     | 374.2  |
| Crated  | 855     | 387.8  |
|         | cu. ft. | cu. m. |
| Volume  | 48.1    | 1.36   |

| Dimensions      | in.    | mm.  |
|-----------------|--------|------|
| Width           | 26-1/2 | 674  |
| Depth           | 33-7/8 | 937  |
| Height          | 61-5/8 | 1565 |
| Floor Clearance | 7-1/2  | 191  |

\*Mounted on standard casters

| Electrical         | Maximum Fuse Size |       | Minimum Circuit Ampacity |       | Poles (P) Wires (W) |
|--------------------|-------------------|-------|--------------------------|-------|---------------------|
|                    | Left              | Right | Left                     | Right |                     |
| 208-230/60/1 Air   | 30                | 30    | 24                       | 22    | 2P 3W               |
| 208-230/60/1 Water | 30                | 30    | 24                       | 22    | 2P 3W               |
| 208-230/60/3 Air   | 20                | 20    | 17                       | 15    | 3P 4W               |
| 208-230/60/3 Water | 20                | 20    | 17                       | 15    | 3P 4W               |
| 380-415/50/3N~ Air | 10                | 9     | 9                        | 7     | 4P 5W               |

This unit may be manufactured in other electrical characteristics. Refer to the local Taylor Distributor for availability.

(For exact electrical information, always refer to the data label of the unit.)

## Bidding Specs

Electrical: Volt \_\_\_\_\_ Hz \_\_\_\_\_ ph \_\_\_\_\_  
 Neutral:  Yes  No      Cooling:  Air  Water  NA

Options: \_\_\_\_\_

## Specifications

### Electrical

Two dedicated electrical connections are required. See the Electrical chart for the proper electrical requirements. Manufactured to be permanently connected. Consult your local Taylor distributor for cord & receptacle specifications as local codes allow.

### Scraping/Ejection Motor

Two, 2.0 HP.

### Refrigeration System

Two, 14,000 BTU/hr compressors (nominal rating). R404A. Separate Hopper Refrigeration (SHR), One, 400 BTU/hr. R134a. (BTUs may vary depending on compressor used.)

### Air Cooled

Minimum 3" (76 mm) around all sides. Install the deflector provided to prevent recirculation of warm air. Minimum air clearances must be met to assure adequate air flow for optimum performance.

### Water Cooled

Water inlet and drain connections under side of base 1/2" FPT.

## Options

Dipping Cabinet (Consult your local Taylor distributor)

Width: 28-7/16" (722 mm)  
 Depth: 17-3/4" (451 mm)  
 Height: 37-1/2" (953 mm)  
 Weight: 175 lbs. (79.4 kg)

Continuing research results in steady improvements; therefore, these specifications are subject to change without notice.