



CROWN
SERIES

TOTALLY DIFFERENT.



Optional Cart with front opening door



Optional Cart with rear door for front mount syrup rail



Optional Top Air Discharge Chute



Standard 6



LISTED
SA2650



Selected 50
Hz. Models

Item No. _____

C709

Soft Serve Freezer

Single Flavor, Heat Treatment

Features

Offer all the popular soft serve variations from low- to non-fat ice creams or yogurt.

Heat Treatment System

Provides a daily heating and cooling cycle to safely maintain dairy products up to two weeks before a complete disassembly and cleaning is required.

Freezing Cylinder

One, 3.4 quart (3.2 liter).

Mix Hopper

One, 20 quart (18.9 liter). Refrigerated to maintain mix below 41°F (5°C) in Auto and Standby modes.

Indicator Lights

Mix Low light alerts the operator to add mix. When the Mix Out light flashes, the unit automatically goes into Standby mode to prevent damage.

Touch Screen Controls

Microprocessor touch controls are embedded in durable tempered glass panel. Multiple languages are selectable. Viscosity is continually measured to serve consistent quality soft serve. Soft lock out features improve reliability. Temperatures in the hoppers or freezing cylinders may be displayed at any point of operation. History of temperatures and times during the last 366 heat cycles may be viewed from the fluorescent display.

Standby

During long no-use periods, the standby feature maintains safe product temperatures in the mix hopper and freezing cylinder.

Door Interlock System

Protects the operator from injury as the beater will not operate without the dispensing door in place.

Continuing research results in steady improvements; therefore, these specifications are subject to change without notice.

Rockton, Illinois 61072
800-255-0626
Phone 815-624-8333 Fax 815-624-8000
www.taylor-company.com
e-mail: info@taylor-company.com

International Office
Taylor Company S.r.l.
Roma, Italy
Tel: **+39-06-420-12002** Fax: +39-06-420-12034
e-mail: romeoff@taylor-company.com

ISO 9001:2008
Registered Firm

C709 Soft Serve Freezer

Shown with optional Air Discharge Chute and Cart

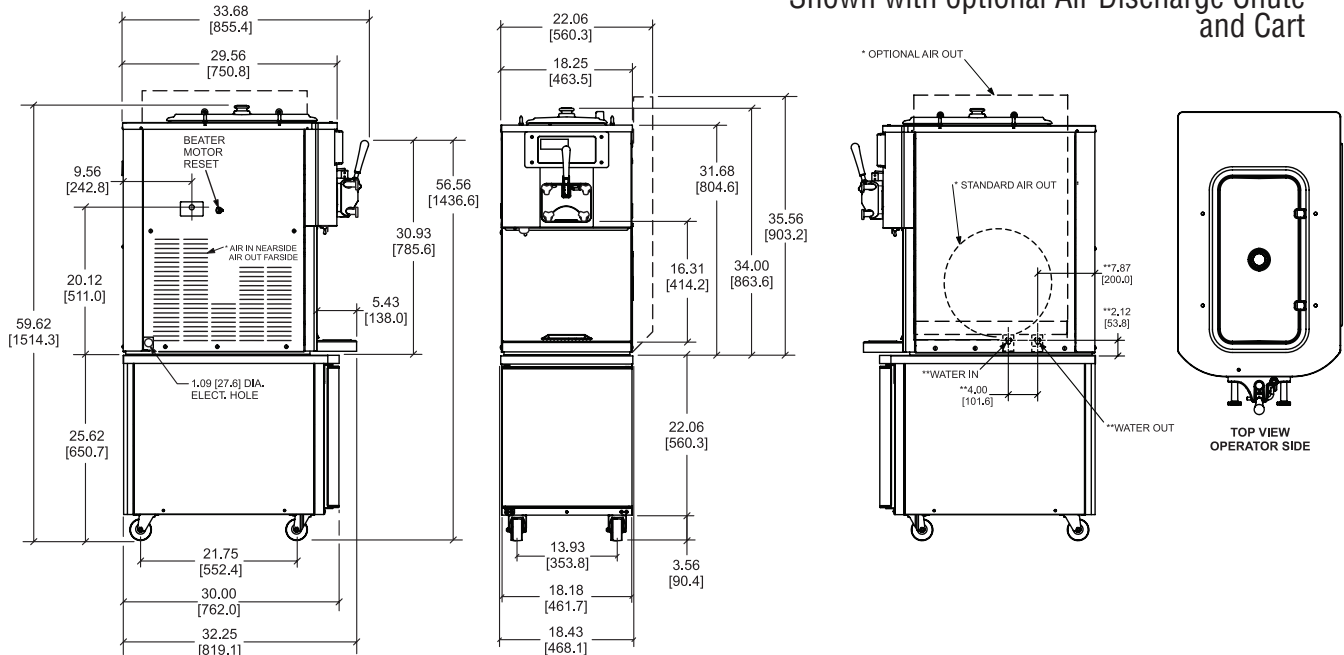

NOTE: * (AIR COOLED ONLY) ** (WATER COOLED ONLY) FIGURES IN BRACKETS INDICATE MILLIMETERS / DECIMAL AND FRACTIONAL DIMENSIONS EQUAL TO (PLUS OR MINUS 1/16 INCH [1.5mm]).

Weights	lbs.	kgs.
Net	414	187.8
Crated	425	192.8
	cu. ft.	cu. m.
Volume	35.0	0.99
Dimensions	in.	mm.
Width	18-1/4	464
Depth	32-1/4	820
Height	34	864
Counter Clearance	---	---

*Designed to rest on a plastic pad directly on the counter top or optional cart.

Electrical	Maximum Fuse Size	Minimum Circuit Ampacity	Poles (P) Wires (W)
208-230/60/1 Air	35	24	2P 3W
208-230/60/1 Water	35	24	2P 3W
208-230/60/3 Air	20	16	3P 4W
208-230/60/3 Water	20	16	3P 4W
220-240/50/1 Air	25	20	2P 3W
380-415/50/3N~ Air	10	8	4P 5W

This unit may be manufactured in other electrical characteristics. Refer to the local Taylor Distributor for availability.

(For exact electrical information, always refer to the data label of the unit.)

Bidding Specs

Electrical: Volt _____ Hz _____ ph _____
 Neutral: Yes No **Cooling:** Air Water NA

Options: _____

Specifications

Electrical

One dedicated electrical connection is required. See the Electrical chart for the proper electrical requirements. Manufactured to be permanently connected. Consult your local Taylor distributor for cord & receptacle specifications as local codes allow.

Beater Motor

One, 1.5 HP.

Refrigeration System

One, 9,500 BTU/hr. R404A.

Air Cooled

Minimum 6" (152 mm) on both sides and place the back of the unit against a wall to prevent recirculation of warm air. Minimum air clearances must be met to assure adequate air flow for optimum performance. Optional air discharge chute directs heated air exhaust upwards. No clearance required on right side if air discharge chute is used.

Water Cooled

Water inlet and drain connections out rear panel 3/8" FPT.

Options

- Cart with casters-height to top of hopper cover: 59-5/8" (1515 mm)
- Cone Dispenser
- Decals - Vanilla or Flavor Burst Cone
- Hopper Locks
- Legs - [increase height of unit by 4-1/4" (108 mm)]
- Syrup Rail (front mount requires special cart with rear door)
- Syrup Rail Kit (side mount)
- Top Air Discharge Chute (air cooled only)

C201 Cart Weights:

Net: 150 lbs. (68.0 kg) Crated: 171 lbs. (77.6 kg) 14.5 cu. ft. (0.41 cu. m.)



Taylor Company,
 Rockton, Illinois 61072
 815-624-8333 **800-255-0626** Fax 815-624-8000
www.taylor-company.com