

Project _____
Item _____
Quantity _____
FCSI Section _____
Approval _____
Date _____



Broaster® 15RBW Snack-Mate™ Radiant Broiler



Standard Features

- *The ideal electric broiler for consistent, high-quality broiling of a wide range of foods.*
- *High intensity infra-red rays cook and warm foods to perfection.*
- *Convenient warming drawer for buns and holding pans for cooked product included.*
- *Compact footprint allows this unit to fit practically anywhere. Perfect for every size operation, from snackshop to full-service restaurant.*
- *Easy clean-up via removeable broiling grid and slide-out drip pan drawer.*
- *Venting Not Required in most areas (check local requirements).*



Specifications

Model 15RBW compact broiling system is of stainless steel construction with easily removable side and rear service panels. Includes single drawer infra-red broiler, slide out drip pan and integrated warming drawer. Comes with two top-mounted 1/3 sized holding pans.

Unit is thermostatically controlled with digital countdown timer for pre-heat and broiling operation. Audible beep indicates completed cook cycle.

Broaster® 15RBW Snack-Mate™ Radiant Broiler

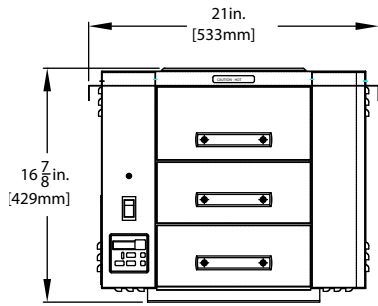

FRONT VIEW

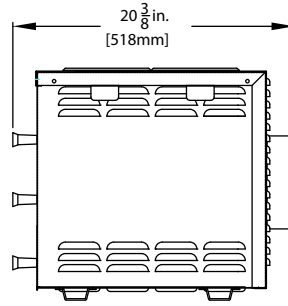

SIDE VIEW

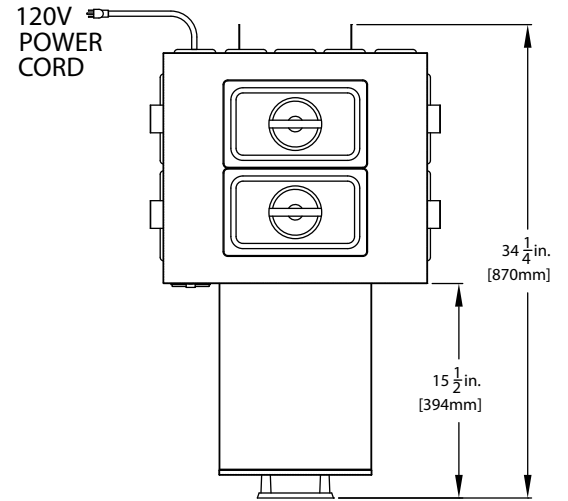

TOP VIEW

Dimensions

Overall Dimensions			Net/Ship Weight 50/59 lbs. (22.7/26.8 kg)	Cubes 5.89
W	D	H		
21"	20-3/8"	16-7/8"		
(533 mm)	(518 mm)	(429 mm)		

Energy Requirements

120V, 60 Hz, 12.5 Amps, 1 Heating Element: 1500 Watts
(3-wire grounded 4' cord & plug included)

Additional Features

- Exterior made of durable stainless steel.
- Easy-to-operate digital timer for accurate cook times.
- Audible beep to indicate completed cook cycle.
- Thermostat keeps broiler preheated, ready to broil when time is set.
- Two 2½" deep, quarter-size, heavy-duty stainless steel holding pans with lids included.
- Side and rear access panels make servicing easy.